

# Chapter — 11

---

## FACILITY LOCATION AND LAYOUT PLANNING

### 11.1 NEED OF FACILITY LOCATION (FACTORY LOCATION, PLANT LOCATION)

Decision of facility location (generally, facility refer to service organization and factory or plant refers to manufacturing organization) is important to any organization whether it is manufacturing or service. Facility location has a significant impact on firm's operation as well as cost structure. Once the location is decided and plant is installed, it is highly expensive to alter the location if it is later known that the location decision was not correct.

Location decision is a *long-term commitment*. Facility location refers to establishment of the physical unit of production process. The physical unit means "plant" where man, material, money, equipment, machinery etc are brought together for manufacturing of product. The need of facility location, factory location or plant location is important for both new enterprises and existing enterprises.

An established company might need the factory location planning for following reason:

- The availability and cost of resources like labor, raw materials and other supporting resources may change.
- The geography of demand may shift. It may be desirable to change facility location to provide before service to the customer.
- As the new market is opened, the added capacity should be located so that the market is served effectively.
- Development of new technologies.
- Socio-Political situations, economic conditions or government policy may change.

Facility location planning is more important for **new enterprises**. The success of organization is also dependent on the location decision. Wrong location decision may doom the business and its existence forever. However, it is very difficult to find ideal and perfect location for any business. So, there is need to analyze the various factors affecting the plant location and take help of mathematical modeling technique to determine the best location decision.

The plant location involves three major activities.

- First to select a proper geographical region.
- Select specific site with this region.
- Find the actual site.

For example one may decide to establish a factory in eastern region. He may then select Dharan for specific site. The actual site with in Dharan decided is Plot no 12546, Bijayapur , Ward no 14.

### 11.2 FACTOR AFFECTING PLANT LOCATION

The production function is associated with conversion of input to desired output by using the appropriate technology i.e. conversion process. The inputs are fed to conversion process, while outputs are marketed. Here, the important factors are **input**, **conversion process** and **market** and these are the **primary factors** affecting location decision. However other minor factors too are important for location decision.

**Nature of the input (raw material):**

In some cases, it is beneficial to locate the factory (plant) near to raw material. If the cost of transportation of raw material is very high comparison to the transportation of finished goods, it is suitable to establish the factory near to input resources. For example cement factory is established near the sources of lime because major input is lime which is very bulky. Similarly, sugar factory is established nearer to sugar cane farm. Other examples are oil refineries, steel industries, and paper industries which are established nearer to source of raw material.

**Nature of output (product or service):**

In some cases it is beneficial to locate the facility nearer to market or potential customer. Service produced by hotels, golf course, church, temples, schools, hospitals, are usually located near the market or the recipients because these services cannot be transported or keep in stock. These facilities should be located within the reach of consumers.

In manufacturing organization, when the product are potential of being damaged or spoiled in course of transportation it is beneficial to establish plant nearer to market. Furthermore, a plant being nearer to the market can catch a big share of the market and can render quick service to the customer. In some cases the transportation of final product to market may be costly compared to transportation of raw material to industry and transportation cost has significant effect, in such case it is beneficial to establish plant nearer to market. For examples soft drink companies like Coca Cola and Pepsi are established nearer to market.

**Nature of technology employed:**

Conversion process and the technology employed also determine the facility location decisions. The conversion process, which produces unfriendly conditions to the people and environment, are usually located in remote areas i.e. far from consumer and the final product and service are transported to the market. The nuclear plant and airport are the good examples.

Other minor factors affecting the location decisions are:

**Availability of labors and their skill**

Stable labor forces of right kind, adequate size (number), and reasonable rates with proper attitude towards works are a few factors which govern the plant location to a major extent. The purpose of management is to face less boycotts, strikes or lockouts and to achieve lower labor cost per unit of production.

**Transport facilities:**

Good transportation facility is an important factor of determination of location. Basic mode of transportation like air, road, rail, water, pipelines are preferred based on the nature of raw material and finished goods. A lot of money is spend on transporting the raw material and finished goods. The location should minimize the cost of transportation.

**Availability of services:**

Services like gas, electricity, water, drainage, waste disposal, communication and other external amenities like shop, community services, communication system etc. are also important

**Suitability of land and climate:**

The topography (geography) of the land also affects plant location. Similarly the climatic conditions e.g. rain fall, humidity, average temperature are also critical factor while determining the location decisions.

**Opportunity for expansion:**

The long range prospective of expansion opportunity must be considered while making location decision. The location should be flexible enough to cover the expansion program.

**Political, cultural and economic situation and regional regulations:**

The political instability may jeopardize the business. Socio-cultural situation like women, foreign worker restriction of working should be considered. The economic condition of locality is important factor to be considered for business like gambling, casino, insurance companies or private educational institutions. Similarly, the study must be made of local regulations before determining the location decisions.

**Special grants, regional tax and import (export) barriers:**

Some local authorities and central government offer special grants, low interest loan, low rental or taxes and other inducement in the hope of attracting certain industries to a particular location. Location of companies to foreign countries to avoid export difficulties are now commonly accepted practices.

After identify the several key location requirement management should find the alternative locations that are consistent with these requirement. These alternative locations are subjected to qualitative and quantitative analysis before determining the exact location decisions.

### 11.2.1 COMPETITIVE ADVANTAGE BETWEEN URBAN, RURAL & SUB URBAN PLANT LOCATIONS

The basis of plant location is first to locate the region and after that to locate the site within that region. Each region may have the urban, rural & sub-urban site. Thus at the second stage the relative merit and demerit of these different types of locations must be assessed.

#### Urban sites (city)

The advantage and disadvantage of urban sites are listed below.

##### Advantage

- Better transportation system
- Larger market
- Right labor force is available
- Availability of services
- Greater easy to finance.

##### Disadvantage

- Low area of land available
- Cost of land and building construction are high
- Expansion generally hard
- Local taxes are high
- Labour salaries are high
- Union problems.

#### Rural sites (Plant sites in small towns)

The advantage and disadvantage of rural sites is as follows:

##### Advantage

- Plenty of land, low cost
- Unskilled labor available, low cost
- Less union problem
- No neighbor problem.
- Municipal, other regulations and taxes are seldom burdensome.
- Government gives inducements to develop underdeveloped areas.

##### Disadvantage

- Skilled labor are not available
- Transportation facility may be inadequate
- Power may be unavailable
- Far market
- Fewer services available.

An alternative between rural and urban is sub-urban sites which being a compromise between the two is probably the most suitable. It possesses the good points of both urban and rural.

### 11.3 GENERAL PROCEDURE IN FACILITY LOCATION

The factory location includes the determination of alternative sites of various geographical regions. These alternative sites are subjected to various qualitative and quantitative analyses to find-out the adequate alternatives among them. The procedure in facility location include

- Preliminary screening
- Detailed analysis that includes qualitative and quantitative models.

#### Preliminary screening

The importance of various factors affecting the location depends on the types of products and service. Some time it is beneficial to locate proximate to marketing where as in other cases it is better to locate proximity to raw material. The factors like labour, transportation facilities, availability of resources, climatic condition, regional regulations, political, cultural and economic situation, has the various degree of effect on the plant location decision depending upon the types of product or service. Hence the preliminary screening is done to alternative sites, with regard to these factors affecting the location decisions. The detailed information regarding these factors could be obtained from local chambers of commerce, local communities, trade publications etc.

**Detailed analyses**

Once the preliminary screening narrows alternative sites to just a few, more detailed analysis is done. This detail analysis involves either *qualitative techniques* or *quantitative techniques* or both.

**A. Qualitative techniques**

Some factors affecting the location cannot be measure in terms of money. The subjective evaluations of sites, regarding these qualitative factors are carried out in qualitative models. These qualitative models are:

- Simple comparative chart analysis
- Factor ratings.

**I. Simple comparative chart analysis**

This method is widely used for analyzing intangible factors affecting the locations decision. The following steps should be followed

- Identify critical intangible factor affecting the location decision
- Compare all the alternative location on the basis of these factors like good / bad, favorable / unfavorable, important /not important etc.
- Select the best location for organization.

The simple comparative chart can be used when an organization does not feel to evaluate intangible factors in details as shown in table.

Intangible factors	Location A	Location B	Location C
Labor supply	Suitable	More suitable	Suitable
Business climate	Good	Very good	Not good
Attitude of community	Unfavorable	Favorable	More favorable
Union activities	Important	Less important	More important

From the above simple comparative chart analysis for intangible factors location 'B' is selected as good one.

**II. Factor Rating Method**

The factors affecting the facility location decision discussed earlier are all more or less important for any type of the organization i.e. the importance of each of these factors may vary for different types of plants. Hence operations managers can use weightings of these factors of the location with respect to the purposed plant or organization to make the location decision more objective. The factor-rating method is most widely used of the general location decision techniques because they provide a mechanism to combine diverse intangible factors in an easy to understand format. The step used in this method to reach to the selection of the location is as follows:

- Step 1:** Identify and note down all the relevant critical success factors to the purposed plant or organization.
- Step 2:** Assign a rate to each factor to reflect its relative importance in company's objectives. Generally these factor are rated from 1-5. A rating of 5 is given to the most important factor and 1 is given to the least important one. These are called factor ratings.
- Step 3:** Take the attractive location alternatives from preliminary screening. Assign the rate to the alternative for each factors according to the benefits a particular location option offers. Generally, these rates varies from 1 - 10. A rating of 10 is given to the most beneficial factor at that particular location. Similarly a rating of 1 is given to the least beneficial factor at that location. These rating are called the location rating. [Note: There is no specific benchmark for factor rate and location rate determination. This is depended on the analytical skill of decision maker.
- Step 4:** Factor rating calculated in step 3 and corresponding location rating calculated in step 4 are multiplied and the cumulative total rating for each alternative location is calculated.
- Step 5:** Select the location with highest total score.

**Example 1:** Location selection for a sugar factory base on the tabulated information

Factors	Factor ratings (1-5)	Location A		Location B		Location C	
		Location rate (1 - 10)	Scores	Location rate (1 - 10)	Scores	Location rate (1 - 10)	Scores
1. Availability of sugar cane	5	8	40	10	50	6	30
2. Transportation	4	10	40	4	16	10	40
3. Labour costs	3	3	9	8	24	6	18
4. Proximity to market	5	7	35	5	25	10	50
5. Power supply	3	8	24	1	3	8	24
6. Governmental/ local rules & regulations	4	9	36	10	40	8	32

7. Environmental rules	3	8	24	9	27	7	21
8. QOL issues	2	10	20	5	10	10	20
9. Banking	1	9	9	2	2	10	10
<b>Total cumulative score</b>			237		197		245

**Conclusion:** Since total cumulative score for the location is highest i.e. 245 hence location C is selected for the purposed sugar factory.

**B. Quantitative Techniques (Models)**

Various quantitative models are used to determine the best locations of facilities. The widely used models for location decisions are

- Simple median model
- Linear programming
- Simulation

**I. Simple median model**

Simple median model is also called *centre of gravity method*. It is a quantitative method for choosing an optimal facility location that minimize cost of transportation based on the median load.

**II. Simulation Method**

Different quantitative models are developed for location decision. These models have their own assumptions, specifications and conditions for application. However in real world (working situations) these specifications, limitations or assumptions may not be applicable or may not be met, reducing the usefulness of these models. Similarly there might be numerous constraints and variable which makes it difficult, handling with quantitative method. Hence to cope with this real complex problem, simulation method is developed. This method is based on the approximation technique.

Besides these three models *other models* are also used for location decision. They are

- Cost benefit analysis
- Locational Break even analysis (BEA)
- Analytical Delphi methods.

**I. Cost Benefit Analysis**

In this method, all the factors affecting the location decision are estimated as cost/unit & those locations is determining where the variable cost/unit is least. This method does not take account the intangible factor. So this method is unsuitable for that situation where in tangible factors e.g. attitude of labor, government regulation or others are major concern. Variable costs per unit of production for two location factor are as follows:

	Location A	Location B
Material	12	8
Labor	8	8
Power	4	3
Taxes	3	1
Insurance	1	2
Transportation	2	4
<b>Total</b>	<b>30</b>	<b>26</b>

Comparing the variable cost per unit of location B is less than Location A, so Location B is selected.

**II. Locational Break-Even-Analysis (BEA)**

Break even analysis can help a operations manager to make an economic comparison of location alternatives by making the cost-volume analysis. The transformation process from inputs to outputs involves two types of costs, namely, the *fixed cost* and *variable cost*.

*Fixed costs* are the capital expenditures which are long-term investments in fixed assets like purchase of the land, construction of building purchase of machines and equipment. These costs remain constant irrespective of the volume of production.

An organization always prefers to have a low break-even volume so that its investments can be completely recovered soon. In facility location planning, a location at which the break-even volume is lower is preferred. The fixed cost and the variable cost may be different at different location options, and hence, these options may have different values of  $V_{BE}$ . In the following BEP analysis of three alternatives A, B and C, the alternative location C is best because it has lower  $V_{BE}$ .

Fig. 11.1 Comparative study of location A,B,C.

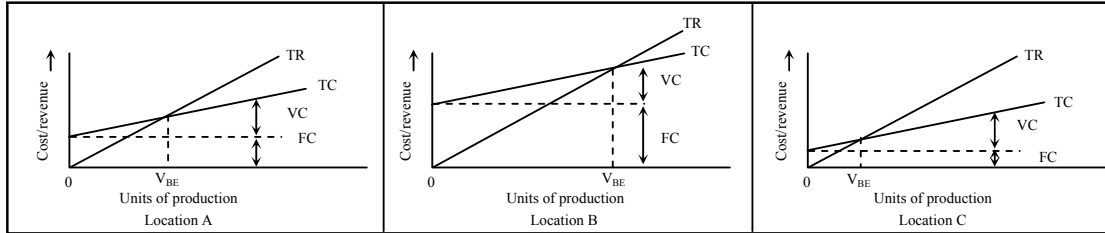

**Steps for locational break-even analysis of the production**

By identifying fixed and variable costs of the production for each location and graphing them for each location, we can determine which one provides the lowest cost. Locational break-even can be done mathematically or graphically. The graphical approach has the advantage of providing the range of volume over which each location is preferable. Following are the steps for locational break-even analysis.

- Step 1:** Determine the fixed and variable cost of the production for each location.
- Step 2:** Plot the costs for each location, with costs on the vertical axis of the graph and annual volume on the horizontal axis.
- Step 3:** Select the location that has the lowest cost for the expected production units.

**III. Analytical Delphi Method**

Most of techniques of location decisions are simply based on criterion such as minimization of cost, time, distance of demand and supply. They do not consider the intangible and emotional issues. Analytical Delphi method is a technique that incorporates both tangible and intangible factors in location decisions.

**IV Rate of return**

This decision is based on the rate of return on the total investment. This situation has been explained with the help of suitable example.

**Solved example 1**

A new entrepreneur wants to set up a small plant. There are three different possible sites A, B, & C. The initial investment (Plant and Machinery) at all the possible sites is of the order of 150000. The entrepreneur decides to take rate of return as the basis to decide the location. The data concerning is as follows:

(i) Sales & distribution costs.	Site A	Site B	Site C
Expected sales	250000	250000	50000
Expected distribution cost	40000	40000	40000
(ii) Expected production cost			
R M & supplies	90000	80000	70000
Power, water, communication	40000	55000	65000
Wages/salary	25000	30000	25000
Other expenses	<u>15000</u>	<u>15000</u>	<u>20000</u>
	170000	180000	180000

Find the best alternatives according to rate of return and interpret the result.

**Solution,**

Here rate of return refers to

$$R = \frac{\text{Annual expected profit}}{\text{Investment}} \times 100\%$$

Those site is selected whose R is highest.

**Calculation of rate of return**

	Site A	Site B	Site C
(i) Sales of distribution cost	250000	250000	250000
Expected sales	250000	250000	250000
Expected distribution cost	<u>40000</u>	<u>40000</u>	<u>40000</u>
Net expected sales receipt (A)	210000	208000	203000
(ii) Expected production cost (B)	<u>170000</u>	<u>180000</u>	<u>180000</u>
(iii) Annual profit expected (A-B)	40000	28000	23000
(iv) Rate of return	$\frac{40000}{150000} \times 100\%$	$\frac{28000}{150000} \times 100\%$	$\frac{23000}{150000} \times 100\%$
	= 26.6%	= 18.6%	= 15%

**Interpretation of solution**

Site A gives 26.6% rate of return and hence can be considered as optimum location. Though cost of raw material is highest in site A (90,000) against 80000 & 70000 respectively for site B & C. The rate of return at site A is highest due to:

- (i) Low distribution cost at site A. The distribution cost at site A is Rs. 40000, whereas distribution cost at site B and site C are Rs. 42000 and 47000 respectively.
- (ii) Low power, water and communication cost of site A. Which are 40000 compared to 55000 & 65000 in B & C.
- (iii) Lower cost of wages and salary compared to B & C.

**11.4 BEHAVIOURAL IMPACT IN FACILITY LOCATION**

On the previous discussions of models, that location is selected which generate minimum total cost of production. However, always location decisions are not based on cost only. Some time unquantifiable factors are critical on taking location decision. In new location, organization needs to establish relationship with new environment and employees similarly; adding or deleting facilities also requires adjustment in the overall management system. The organization structure & modes of making operating decisions must be modified to accommodate the change. The cost associates with these changes are called "**hidden system costs**". These costs are usually excluded from quantitative model's thought they are very real aspects of the location decisions. Some behavioural aspects of facility locations are:

**Cultural differences**

At national level, locating new facilities generally require hiring the employees in local circumferences. The organization must recognize the differences in the way people in various ethnic, urban, suburban and rural communities react to new business. Managerial style and organizational structure must adapt to the norms and customs of local subcultures. Employees' acceptance of authority may vary with sub culture. Sub-culture also affects employee's goals, beliefs about the role of work, career aspirations, and perceptions of opportunity. These cultural variations in attitude influence the job behavior and talents of individuals. Similarly; organization must establish appropriate community relations to fit into the location as a good neighbor and citizen.

At the international level, there are even greater cultural differences e.g. Japanese & Americans & Europeans have versatile cultural differences. Locating a new facility in a new culture is not simply an establishing of efficient manufacturing process, however it needs the borrowing of managerial techniques & skills as and when required from these culturally varied society. Obviously, the economic, political & cultural make up of a society has far-reaching effects on the technological & economic success of multinational location decisions.

**Job satisfaction**

In recent years managers have been very concerned about employee job satisfaction, because it affects how well the organization operates. Job satisfaction has a direct favourable impact on the individual productivity. Employees with positive satisfaction towards job generally show the following characteristics.

- Fewer labour turnovers
- Less absenteeism
- Less tardiness
- Fewer grievances.

These mentioned four characters have substantial affect on both cost and disruptions of operation. Some times job satisfactions are also found related with other community characters such as community prosperity, small town versus large metropolitan locations, unionisation etc.

### Customer considerations

For many organizations, location planning must emphasize consumer behavior and proximity to customers. If primary product is a service to the public, the customer convenience will be the prime consideration. Theatres, banks, supermarkets and restaurants heavily emphasize customer convenience when choosing the locations. In fact location convenience itself is often considered to be the service. For these reasons the location decisions may be regarded as a responsibility of marketing staff instead of production/operation staff, especially as it, affects revenues value than cost.

## 11.5 FACTORY LAYOUT CONCEPT

*Plant layout* means the disposition of the various facilities (equipments, materials, human resources) and utilities of the plant within the area of the site (location decision) selected previously. Plant layout begins with the *design* of the factory building and goes up to the location and movement of individual work table. All the facilities like equipments, raw materials, machinery, tools, fixtures, workers etc. are given a proper place so that the objective of lay out will meet.

### 11.5.1 OBJECTIVES OF LAYOUT

In a good plant layout, the following objectives are met.

- Handling & transportation of material is minimized.
- Bottlenecks and points of congestions are eliminated (by **line balancing**) so that the raw material and semi-finished goods movement is faster.
- Workstations are designed suitably & properly.
- Suitable spaces are allocated to production and service centre.
- The movements made by workers are minimized.
- Waiting time of the semi-finished goods is minimized.
- Working conditions are safer, better & improved.
- There is an increased flexibility for changes in product design and for future expansion.
- There is a utilization of cubic space (length / width / height)
- There are improved work methods and reduced production cycle times.
- Plant maintenance is simpler.
- There is increased productivity and better product quality with reduced capital cost.

### 11.5.2 PRINCIPLES OF PLANT LAYOUT

There are various layout principles; however considerable arts & skill are required in designing a good plant layout. The research work is being continued in order to develop a scientific approach for solving plant layout problems. Out comes of those research are the development of *heuristics approach, mathematical models and computer aided computational* techniques for balancing the assembly line.

The few principles for sound plant layouts are:

- Integration
- Minimum movement & material handling
- Smooth & continuous flow
- Cubic space utilization
- Safe & improved environment
- Flexibility

**Integration:** It means, integration of production centers facilities like workers, machinery, raw material etc in a logical & balance manner.

**Minimum movement and material handling:** The number of movements of workers & material should be minimized. It is better to transport material in optimum bulk rather than in small amounts.

**Smooth and continuous flow:** Bottlenecks, congestion points & back tracking should be removed by proper line balancing technique.



**Cubic space utilization:** Besides using the floor space of a room, if the ceiling height is also utilized, more materials can be accommodated in the same room. Boxes or bags containing raw material or goods can be stocked one above the other to store more items in the same room. Overhead material handling equipments save a lot of valuable floor space.

**Safe and improved environments:** Working places should be safe, well ventilated and free from dust, noise, fumes, odor and other hazardous conditions. This will increase the operating efficiency of the workers and also improve their morale. All these lead to satisfaction amongst the workers & thus better employer- employee relationship.

**Flexibility:** In automotive and other industries, where models of product change after some time, it is better to permit it all possible flexibility in the layout. The machinery is arranged in such a way that the changes of the production process can be achieved in the least cost or disturbance.

### 11.5.3 FACTORS INFLUENCING PLANT LAYOUT

The objectives of lay out are affected by various factors. Some of the major factors (But not limited) are as follows:

1. **The material factor:** This includes design, variety, quantity, necessary operation and sequence of various material (Raw material, work in progress goods, finished goods) used in production system.
2. **The machinery factor:** This includes the producing equipment, tools & their utilization.
3. **The man factor:** This includes human resources employed in production system for supervision, service, direct and indirect direct workers.
4. **The movement factor:** This includes inter-intra departmental movement of man and material factors for transport and handling and inspection at the various operations of production function.
5. **The waiting factor:** This includes permanent & temporary storage of finished goods, semi finished goods or raw materials are delayed for dispatch or processing.
6. **The service factor:** This includes maintenance, inspection, waste, scheduling & dispatching.
7. **The building factor:** This includes outside and inside building features, utility distribution and equipment.
8. **The change factor:** This includes versatility, flexibility & expansion.

### 11.6 TYPES OF LAYOUT

It is quite difficult to distinguish the lay out type because, the production lay out are now made more flexible to achieve the versatility of service and goods as per customer requirement. However in broad aspects, lay out are classified as follows:

- Process layout (Functional layout)
- Product layout (Assembly line)
- Combination layout
- Fixed position layout

#### 11.6.1 PROCESS LAYOUT

Process layout is characterized by keeping similar machines or similar operation at one location (place). This is also called *functional lay out* because machine are arranged according to their function. Taking an example of a work shop, all lathes will be at one place, all milling machines at another and so on. This type of layout is generally employed for industries engaged in job order production and non repetitive kind of manufacturing or maintenance activities. In the figure 11.7., it is seen that all lathe works are done on lathe section which consists of one or more lathe machine as required. Similarly, all the milling works are carried out on milling section where milling machines are placed and so on. For example a machine shaft has to be made which consist of shaping, drilling, milling and lathe operation. For that the component is issued from the store, it is that carried to

shaper section where shaping is done, then to drilling section where drilling is done on the shaped component. Similarly, it is carried to milling and lathe operation. The final component are inspected on inspection department and finally issued to store.

**Fig 11.7 Process layout**

Store room	Inspection department	Broaching section	Milling section
Lathe Section	Shaper section		
Drill section		Stock Room	

**Advantages:**

- Wide flexibility exists as regards allotment of work to equipments and workers
- Better utilization of the available equipments.
- Comparatively less number of machines is needed, thus involving reduced capital investment.
- Better product quality because, supervisors and worker attend to one type of machines and operations.
- Varieties of jobs make the work more interesting for the workers.
- Workers in one section are not affected by the nature of the operation carried out in another section. For example, a lathe operator is not affected by the rays of the welding, as the two sections are quite separate.

**Disadvantages (compared to product layout):**

- For the same amount of production, process layout needs more space.
- Automatic material handling is more difficult.
- More material in process remain in queue for further operation
- Completion of same product takes more time.
- Work-in-process inventory is quite large.
- Production control becomes difficult and also needs skilled manpower to carry out variety of job in single machine.
- Raw material has to travel larger distance for being processed to finished goods. This increases the material handling and associated costs.
- It needs more inspections & efficient co-ordinations.

Some example of functional (process) lay out are: nursing homes, hospitals, universities, office building, work shop, tailor shop, printing process etc.

**11.6.2 PRODUCT LAYOUT**

It is also known as *line layout*. It implies that various operations on the raw material are performed on sequence and the machines are placed along the product flow line. It means, machines are arranged in sequence in which the raw material will be operated upon. This type of layout is preferred for continuous production which involves continuous flow of in-process material towards the finished product stage. Some examples are textile, sugar, instant noodles, paper mills etc. From these examples it is seen that product layout are suitable for high volume production system, producing very limited or single variety products. As we know, in sugar only sugar related products could be produced. This lay out is specialised for high volume unique products making highly inflexible.

Fig 11.8 Product Layout

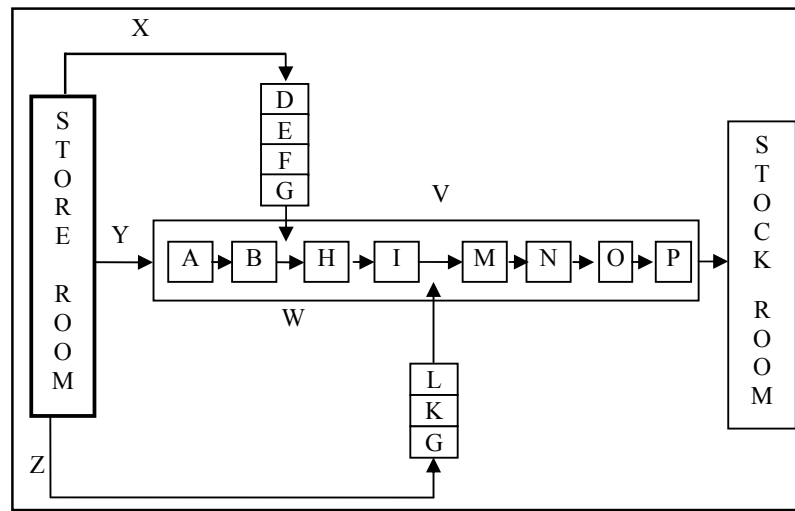

Raw material from the store is fed to three lines X, Y, and Z. Material in X lines gets processed on machine D, E, F & G and meets material of Y line after it has been processed on the main assembly line machine A & B. Products of X and Y lines are assembled at W and get processed on the machine H and I till another parts comes from Z line and assembles with main product at V. After that the total assembly gets worked on machine M, N, O and P and final products are send to stock room.

#### Assumptions for product layout

1. Volume is adequate for high equipment utilization.
2. Product demand is stable enough to justify high investment in specialized equipment.
3. Product is standardized or approaching a phase of its life cycle that justifies investment in specialized equipment.
4. Supplies of raw materials and components are adequate and uniform quality (adequately standardized) to ensure that they will work with the specialized equipment.

#### Advantages (compared to process lay out)

- Less space requirements for the same volume of products compared to process lay out.
- Automatic material handling, lesser material handling movements, times and cost.
- Less in process inventory.
- Product completes in lesser time.
- Better co-ordination and simple production planning & control
- Smooth & continuous workflow.
- Less skilled workers may serve the purpose.

#### Disadvantages

- The layout is inflexible.
- The pace or rate of working depends upon the output rate of the slowest machine. This involves excessive idle time for other machines if the production line is not adequately balanced.
- Machine being scattered along the line, more machine of each type are required for keeping them stand by, because if any machine in the line fails, it may lead to shut sown of the complete production line. This is how product layout involves higher capital investment.
- Though it involved less supervision as compared to process layout, some times it (inspection) becomes difficult when one inspector has to look after many (say all welding) machines in two or more production lines.
- It is difficult to increase production beyond the capacities of production line.

### 11.6.3 COMBINATION LAYOUT

Combinations of process and product layout are usually used to acquire the advantage of both layouts. More ever, in these days' pure product or process layout are rare. A combination layout is possible where items are being made in different type and sizes. In such cases, machinery is arranged in a process layout but process grouping (a group of number of similar machine) is than arranged in a sequence to manufacture various types and size of products. The point to be noted is that, no matter the product varies in size and type, the sequence of operation remains same or similar in combination layout. In the following figure of Combination layout, F, G, H, I represent different machine and 1, 2, 3, 4, 5 represent the similar type of machine. Here same machine are arranged in process lay out, however different machines are arranged as product lay out.

Fig11.9: Combination Layout

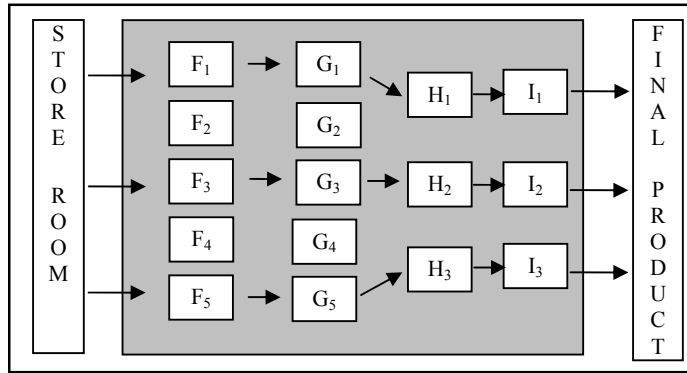

A combination layout is also useful when numbers of items are produced in same sequence in fewer amounts (i.e. not on bulk) and it is not advantageous to have single production line for each product. For example refrigerator & TV manufacturers use a combination layout. First of all, they use process layout for manufacture of parts and components. However they use product layout for final assembling of products. To sum up, in combination layout, fabrications are normally handled with a process layout, where as assembly operations are carried out by product layout.

### 11.6.4 FIXED POSITION LAYOUT

In other types of layout discussed earlier, the product moves past stationary production equipment, where as in this case the reverse applies; men and equipment are moved to the material, which remain at one place and product is completed at that place where the material is fixed. Layout by fixed position of the product is inherent in ship building, aircraft manufacture and big pressure vessels fabrications.

#### Advantages:

- It is possible to assign one or more skilled workers to a project from start to finish in order ensuring continuity of work.
- It involves least movement of materials.
- There is maximum flexibility for all sorts of changes in product and process.
- A number of quite different projects can be takes with the same layout.

#### Disadvantages:

- It usually involves a low content of work-in-process.
- There appears to be low utilization of labor and equipments.
- It involves high equipment handling costs.

#### Application:

Layout by fixed position of product is limited to large items made singly or in very small lots.

## 11.7 BEHAVIOURAL ASPECTS IN LAYOUT DESIGNING

### 11.7.1 BEHAVIOURAL ASPECTS IN PROCESS LAYOUT

Operation manager must consider individual and group behavior when planning a process oriented layout. Layout can affect both employee relationship and customer satisfaction.

**Individual and inter personal behaviour of employees:**

In process layout physical facilities are arranged according to their functions. All these either hinder or facilitate the interpersonal relationship. In other words it groups the workers according to their skills. They establish their own norms and affiliations. These norms should be compatibles with management standards (but not always) as the result it will raise (or minimize) employees’ satisfaction, motivation, labour relation, performance and ultimately the productivity. Therefore while designing layout, all the interpersonal and group behaviour, relations and coordination should be considered. This should ensure less absenteeism, less turnover, high motivations, job satisfaction and productivity improvement.

**Customer Behavior**

If customers participate in conversion process, layout determines the quality, speed of service as well as their satisfaction. Therefore customer satisfaction becomes a major consideration in layout planning for those organizations. Some examples are bank, insurance, restaurants hospital etc. In such case, layout designer should be competent in design facilities considering all the behavioral aspects of customers.

**11.7.2 BEHAVIOURAL ASPECTS IN PRODUCT LAYOUT**

Organization that produce large volumes of a single or limited variety of products benefit from a product oriented (assembly line) layout. The major behavioral issue in product- oriented layout involves *employees satisfaction, motivation, interest and productivity*. Few decade ago , it was assumed that ever increasing job specialization would lead to increase labor productivity, however development of behavioral management has shown this assumption to be true, but only up to a point. Some time routinization leads to job dissatisfaction, absenteeism, and higher employees' turnover. This negative response to job specialization can be minimized through quality circles, job enlargement, enrichment and rotation.

**11.8 COMPARISON OF BASIC LAYOUT**

The fundamentals differences between product oriented, process oriented and fixed layout are discussed in table 11.3

**Table 11.3 Difference between three types of layout**

<b>Basis</b>	<b>Product oriented</b>	<b>Process oriented</b>	<b>Fixed position</b>
Product	Standardized product, large volume, stable rate of output	Diversified product, varying volume, varying rate of output.	Made to order, low volume.
Work-flow	Straight line, same sequence of operation for each unit.	Variable flow, different sequence of operation	Little or no flow of material but human come to site.
Human skill	Highly specialized, routine & repetitive task	Primarily skilled performed with less supervision	Greater flexibility, work & location vary
Material handling	Flow, predictable, systematized, can be automated.	Variable flow	Variable flow, general purpose handling equipment needed.
Inventory	High turnover of raw material and WIP inventory.	High raw material inventory, low turnover of raw material and WIP inventory	Variable inventories, frequent tie-up as production cycle is long
Capital requirement	Large investment in specialized equipments and process	General purpose flexible equipments and process	General purpose, mobile equipment and processes.
Product cost	Relatively high fixed cost, low unit cost for direct labor and materials	Relatively low fixed cost, high unit cost for direct labor, material & material handling.	Relatively low fixed cost, high unit labor & material cost.
Space utilization	Efficient utilization, large output per unit space.	Large WIP space requirement, small output per unit space.	Small output per unit space if conversion is on site.

## 11.9 METHODS OF PLANT AND FACTORY LAYOUTS

A layout furnishes details of the building to accommodate various facilities (like workers, materials, machinery etc). In addition, it integrates various aspects of the design of production system. The information required for plant lying out includes, dimensions of work places, sequence of operations, flow pattern of materials, storage space for raw material, in process inventory and finished goods, offices, toilets etc. There is no single universal technique leading to best layout. Various techniques independently or in conjunction with other techniques may be employed at different stages involved in plant or factory layout. The word plant or factory can be taken more or less as synonyms.

The following methods may be used while developing a layout in sequential order.

- Process flow chart
- Material movement pattern
- Layout analogues
  - Templates
  - Three dimensional models
- The correlation chart
- Travel chart
- Load path matrix

The initial stage of the development is process flow chart. They show how different component parts assemble in sequence of operation to form sub-assemblies, which in turn lead to assemblies (finished products). Secondly, the flow pattern of material in process is traced and layout is built around it. Once the material movement patterns are determined, layout analogues are developed. These analogues are:

1. Templates
2. Three-dimensional models.

### Templates (Cut outs)

They are used to develop plant layout. They are two-dimensional or block templates made up of cardboard, colored paper or celluloid. They are made to scale (*e.g. 1: 50*) and are placed on the scaled outline plan of the building. Templates or cut outs show the plan of the various facilities and the buildings. They show the actual flow floor space utilization. These templates have flexibility in use and can be moved on the graph paper from place to place in order to evaluate various feasible positions for different machines.

### Models

They are the scale models of a facility and more clear to the real situation as besides length and width they show the height of a facility also. Models are used mainly to develop floor plans and elevations. Models can be made for production machine, workers, material handling equipment or any other facility. Models are much more effective and fast as compared to drawings or templates especially when multi storey plant layout is to be designed. Multi storey models can be made of a clear plastic.

The *correlation chart*, *travel chart* & *load path matrix* are the mathematical model to have the optimum layout which minimize the material handling, material flow of cost of transportation.

These help to determine the layout of one facility with relation to other department. These help to increase the efficiency of existing plant layout

## 11.10 THE DYNAMICS OF LAYOUT

A layout should be flexible enough to permit future changes in production technology, change in product design or change in production mix. In a sense all layout are flexible and could be changed by allocating cost. However in good layout flexibility is achieved at minimum cost.

The development of good layout depends upon a series of previously made decisions on various factors like; location, capacity, facilities, manufacturing method, product mix and other activities including position of equipment, the flow of material and material handling.

In considering the layout of a new plant or in re-designing and one, basic managerial decision must be made about the required output levels and the operations of the plant. The concepts of **external** and **internal** balance are two basic criteria often used to determine capacity level. External balance is defined as the matching of plant capacity to projected sales or demand, where as internal balance is defined as the balancing of the internal operation to eliminate production bottlenecks and yet produce the desired output. Application of these criteria leads to the matching of production capability at each step of the manufacturing process.

**External balance**

In assessing external balance, the manager seeks to equate productive capacity with the expected level of sales demand. There are three commonly accepted methods of achieving external balance.

1: Design the facility to meet the peak demand.

On this criterion, production capacity is set to meet the expected peak demand. This would help to maintain of minimum inventories even in the largest sales demands. In this condition, the use of equipment and labour would be subjected to wide fluctuations because there will be an ideal capacity below the peak level of production.

2: To design the physical facility to meet average demand

In this criterion, production capacity is set to meet the average sales demand. The main objective is to establish a steady production rate that will just satisfy the normal annual demand for the firms' products. Using this approach, however, it will be necessary to accumulate and maintain inventories to meet sales demand of peak periods.

3: To design the physical facility to meet the low point in demand

In this criterion, production capacity is set to meet the low sales demand. Here, labour and equipment utilization is highest because the plant has to be operated in full capacity to meet the demand. This will minimise fluctuation in the level of activities. As the output is only able to satisfy the low sales demand, the inventory levels would be at very minimum or none. Thus manufacturer will be unable to supply normal or peak demand. Management faces the problem whether to allow the excess of demand over production to fall to competitors or to sub contract this amount. The latter approach is the basis for "tapered vertical integration".

**Internal balance**

Internal balance is the equalization of capacities in successive stage of the production process. Once the decision on overall capacity or external balance has been made, the problem is simply to provide the correct capacity at each stage of the process so that the production flow is well balanced. A simple illustration for internal balance is shown in table 11.4.

Table 11.4 : Internal balance

Machine name	Relative standard time or each operation.	No. of machine required to achieve internal balance
1. Turret lathe	2 min.	1
2. Milling machine	4 min	2
3. Drill press	8 min	4
4. Shear	2 min	1

The process flow sequence is as follows:

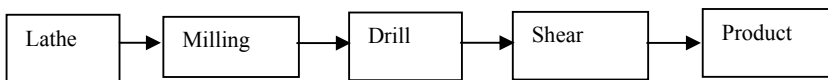

If the internal balance is not done, a unit production will require 6 minutes of time. Because though, turret lathe machine and shear machine require only 2 minutes processing time, milling machine and drill machine are bottle necks that require respectively 4 and 8 minutes. To have the internal balance four number of drill machine and two number of milling machine are required, this reduces the processing time per unit production to only 2 minutes. The balances system could be shown as:

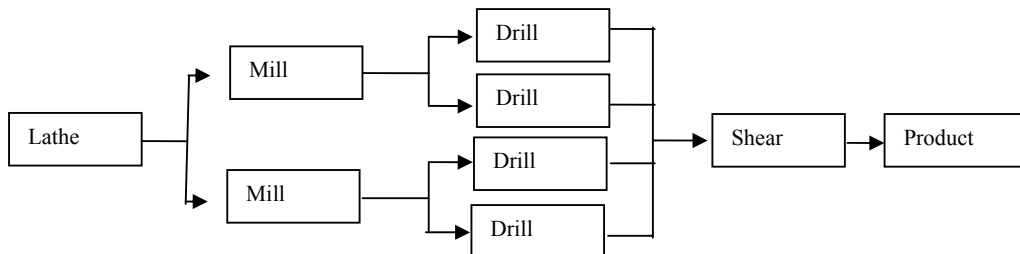

By this line balance we will be able to produce a product in conjunctive 2 min., compared to 8 min. in previous one, and there is no idle capacity in any machine. Situations that are shown in example are very rare. The output volume set for a plant as a whole by external balance decision would generally necessitate fractional quantities of machines if the desired output were to be obtained precisely. The same problem is encountered when attempting to balance workloads on production lines that are mechanically paced. Perfect balance would require the workload of all workers to be precisely equal, yet this arrangement is extremely difficult to maintain.

If the output at any stage (position) along the line is below what is needed to match the output of previous stage, a bottleneck will result. On the other hand, if the line is paced to meet the slowest output along the line, costly capacity would remain idle part of every day. This dilemma is one of the most difficult problems to be resolved in the design of automated production process. The task of balancing internal balance becomes more complex when many products are manufactured on the same equipment.

If small fractions of machines are required in order to achieve balance, over time or sub-contracting are often employed instead of investing in additional machinery. For example, the machine at bottlenecks position may be operated ten or twelve hours a day, to match the output from machine at other position in an eight hours day. Additional storage space must be produced in such case to hold the larger amount of WIP inventories that are created.

In performing internal balance calculations, it is important that actual experience be used as the basis of computation rather than projected theoretical output levels. Output levels in a plant are seldom precisely equal to the calculated standard output. Workers may produce above or below the standard. Consequently, when experience data on actual output level are available they should be used.

A well balance line has a very low balanced delay. These balancing problems could be solved by various approaches such as:

- Computer sampling
- Trial and error approach
- Dynamic programming
- Heuristic methods.

### **11.11 LAYOUT PROCEDURE**

The ideal procedure for a plant layout is to build the layout around the productive process and then design the building around the layout. This may not be possible always, because the plant building may already be existing or shape of plant may not permit the construction of a building to house the productive process, etc. Ultimately, one has to strike a balance between the two approaches. However, various procedural steps involved in plant layout have been listed and described below:

**a. Accumulate basic data**

The basic data includes:

- Volume and rate of production.
- Product specification and bill of materials.
- Process sheets indicating tools, equipments, the method and the product which will be manufactured.
- Flow process charts.
- Standard time to complete each operation, etc.

**b. Analyze and coordinate basic data**

The basic data are analyzed and coordinated in order to find

- The workforce and size and type.
- Number of work stations required
- Type of equipment required
- Storage and other space requirements.
- Assembly chart and operation process chart help coordinating data.

**c. Decide the equipment and machinery required**

Number of equipments required to meet a particular production target can be calculated by knowing the following parameters.

- Number of articles to be produced
- Capacity of each equipment



- Time in which the order is to be completed, etc.
- d. Select the material handling system.**  
The material handling system is selected for moving raw material, semi-finished goods and final products. The type of material handling equipment to be selected depends upon:
- Material/product to be moved
  - Container in which it will be moved
  - Length of movement
  - Frequency of movement
  - Speed of movement, etc.
- e. Sketch plan of the plot for making factory building**  
Sketch plan for the plot to mark building outline, roads, storage and service areas, etc.  
The plan orientation should utilize maximum, the natural heat light and other weather conditions.
- f. Determine a general flow pattern.**  
Machinery may be laid as per production p[rocess requirements and plant building be erected about the same. The flow pattern of materials should be such that the distance involved is least between the store and the shipping department through the production centers .There should be minimum back tracking and bottlenecks. Flow patterns may be analyzed using operation process charts or travel charts in case of multiple flow patterns .Based upon the process or product requirements, one may adopt process layout, product layout, or a combination layout. Plant layout should be flexible so that it can accommodate changes in product or product diversification
- g. Design the individual work station.**  
Each work station should be laid for achieving optimum performance of operations, materials and space utilization, safety and comfort of employees etc.
- h. Assemble the individual layout into the total layout.**  
Once the individual work station is designed , the next step is to assemble the individual layout into the total layout in accordance with the general flow pattern and the building facilities.
- i. Calculate storage space required.**  
The storage space can be calculated by knowing the volume of each store item, number of items to be kept in store, the time each item may be kept in store etc.
- j. Make flow diagrams for work stations**  
The next step is to make flow diagrams for work stations and allocate them to areas on areas on plot plan.
- k. Plan and locate service areas.**  
Service area like office, toilets, wash rooms, tool rooms, rest and launch room, cafeterias, dispensary, power generating areas and packing area etc are planned and allocated.
- l. Make master layout**  
The next step is to built the master layout by using the templates and models
- m. Check final layout**  
Once the master layout is prepared, it is checked as regard to following layout principle aspects:
- Integration
  - Minimum movement & material handling
  - Smooth & continuous flow
  - Cubic space utilization
  - Safe & improved environment
  - Flexibility
- n. Get official approval of the final layout.**  
After the final plant layout has been checked, it is got officially approved and signed by the team which checked the final layout. The final layout accompanies information like product drawings, bill of materials, assembly and operation process chart, manpower requirement, equipment requirement, estimated expenditure and revenues etc depending the layout type and scale of production.
- o. Install the approved layout.**  
Once the official approval has been obtained, detailed plan for installing production , service and other centers are made and carried out accordingly.

## 11.12 BUILDING FOR PLANTS

### 11.12.1 FACTOR AFFECTING THE BUILDING DESIGN

After the plant location has been selected, and plant layout decided upon the next step is to construct the plant or factory buildings to house or protect employees, equipment, tools, machinery, materials etc. A good factory building carries following functions.

- (a) Helps performing different operation most effectively
- (b) Reduce material handling costs.
- (c) Minimize production circle time.
- (d) Reduce bottlenecks, stoppage and interruptions.
- (e) Increase down the maintenance cost.
- (f) Lowers down the maintenance cost.
- (g) Increase equipment and employees safety.
- (h) Has good appearance and provide healthy and pleasant working conditions.

While constructing the factory building flexibility and expandability are major considerations. Other factors to be considered while constructing/ designing factory are:

- Type of process : Batch production  
: Continuous production  
: Assembly line
- Flexibility desired
- Expandability desired
- Service facilities
- Employee facilities
- Lighting
- Heating
- Ventilating
- Air-conditioning
- Other considerations like good appearance, Strong, durable, economical, safe construction, Security measure, Noise control etc.

#### Nature of Manufacturing Process

Buildings required to house continuous or intermittent production processes differ quite a lot in their design. Seldom is the same building suitable for both these types of productions. Building design varies with the type of product to be manufactured and the equipment utilized. Buildings manufacturing rubber tyres, clothes, machine tools, glass bottles, presses or steel plates possess designs which differ as regards floor loading, height of the ceiling, bay size, ventilation and humidity requirements, etc.

#### Flexibility

Suppose a factory owner is interested to leave his original product and decide to manufacture another product which he feels is probably more profitable. He cannot construct another building and thinks of using the same old factory building for making the new product. This is not strange; many old cotton mills and sugar factories are now being used for light engineering works. At this stage the question arises, whether the old factory building is flexible enough to be used for manufacturing the new product? Thus, flexibility in factory building avoids it from becoming obsolete and imparts to it (*i.e.*, to the building) the same operating efficiency even when there is a change in product, process or technology. The flexibility of factory building *can be increased* by:

- Providing a large floor area unobstructed by pillars, columns, etc., so that processes and layouts can be changed easily;
- Keeping adequate roof truss strength and ceiling height so that newer material handling equipment can be installed and inside building temperatures may be controlled;
- Erecting no permanent obstruction such as walls and partitions on the production floor;
- Providing individual motor drives for the machines;
- Providing overhead electrical grid so that electrical supply (at various voltage levels) can be tapped near the equipment;
- Making heavy duty floors to accommodate even heavier machines;
- Making machine installations such that the machines can be moved easily when layout changes are required.

### Expandability or Future Expansion

Keeping provision for future expansion has become very necessary because of the enormous expansion of industry in recent years. Due consideration is being given to future expansions while designing a new building; but before that a plant site size large enough for current needs and for future expansion requirements should be purchased. While designing the factory building, it is thought of carefully that in future, whether the building will expand length or breadth-wise or more number of floors will be constructed. If it is decided to expand length- and breadth- wise, false and non- load bearing end walls are constructed to make expansion easier. If more floors are to be added in the building above the ground floor, adequate foundations, supports, etc., should be provided in the original structure to carry the weight of added floors. Where processes are housed in separate buildings, certain plan shapes have become popular due to their ease of extension (expansion) and they are in the form of the letters *F, E, H, U, L, T*, etc.

### Service Facilities

Service facilities such as fire fighting equipments, sewage- treating systems, emergency and standby power equipments, compressed- air equipments, heating, lighting, ventilating and air- conditioning equipments, etc., should be housed separately and suitably.

### Employee Facilities

Good employee facilities are incentive to the employees of an organization and they build up the morale of the employees. Adequate provision should be kept in regards washroom and toilet facilities, dispensaries, cafeterias, recreation rooms, parking areas etc.

### Lighting

One of the most important environmental factors is Lighting which increases productivity, reduces accidents and adds to employee satisfaction.

#### Advantages of Good Lighting:

- Increased output, therefore decreased costs,
- Reduced accidents,
- Improved product quality,
- Better visibility, therefore less strain on the eyes,
- Less spoilage and consequent rework,
- Better floor space utilization and improved house- keeping,
- Plant neatness and cleanliness can be better maintained.
- Easier and better supervision of materials in process and finished products, and
- Improved morale among employees resulting in reduced labor turnover.

#### Characteristics of Good Lighting

- Light should be of sufficient intensity for the particular operation being performed.
- Light should be equally bright throughout the shop floor.
- Light should be diffused and not glaring.
- There should be adequate but not sharp contrast between each part of an object and from the surrounding background.
- Light should not permit marked shadows.
- Dazzling light should be avoided.

#### Nature of Light

**Natural light** : It is actually the best for working, but it varies with the time of day, time of the year and weather (cloudy) conditions. It also varies with the size and position of windows and moreover it is just not possible to regulate the intensity of natural lighting. This necessitates the use of *artificial lighting*.

**Artificial lighting** : It is designed in such a way that it should supplement natural lighting. Artificial lighting, during day time, serves only those areas, which do not have enough light to work.

#### *Artificial Light Sources*

- Tungsten filament lamps,
- Fluorescent tubes, and
- Mercury vapour lamps.

*Tungsten filament lamps* are inexpensive, easy to install and are available in different wattage ranges. But they have low rate of efficiency, need shielding to eliminate glare and

therefore are used only for local lighting. They have been replaced by fluorescent lamps and tubes. *Fluorescents lamps and tubes* have best efficiency rate and are in very common use in factories. Their current composition is less, they have a low brightness rating, longer life and are available in a number of colors. However, sometimes they cause stroboscopic effect when looking at rotating parts and create maintenance problems because they are being used in large number even in an average installation. *Mercury vapour lamps* have a high brightness, easy to maintain and have long operating life. Its greenish blur light gives an unnatural look. Mercury vapour lamps are used in large machine shops, hangers, and in high bays for general industrial lighting. Reflectors may be employed for getting direct, diffused or indirect light.

**Heating**

In a factory, heating is required for following purposes:

*Processing:* Heating is required for melting metals and alloys, making forging or other material processing, *Work place heating.* Work place is heated for improving the efficiency of the workers in the winter season. The temperature maintained is within the comfort zone of about 60-65°F. The source of heating are various types like electric, choke or oil furnace, electric heaters, gas heaters, stoves etc.

**Ventilating :**

It is basically a replacing stale air by fresh air. If the stale air is not removed, it will smell bad and the concentration of carbon-di-oxide, humidity and temperature will rise. Inadequate ventilation result in discomfort and fatigue. Modern plants provide ample opportunity for good ventilation by natural ventilation or by using artificial mechanical type ventilation.

**Air - Conditioning**

Air conditioning is the control of air temperature, humidity, cleanliness and distribution of air. It is done basically to have precise controlling of machine (avoid error due to temperature, humidity change), , enhance working environment thus increase productivity of workers. Some machine require the air conditioned environment like tetra pack machine. Similarly, air condition is also done to check microbial and other physical, chemical hazard from air.

**Other consideration :**

The building should have a good appearance, strong , durable and safe construction. There should be proper safety and security measures installed. Similarly provision should be made for the noise control.

**11.12.2 TYPES OF BUILDING**

The following are the major types of buildings:

- Single storey building with different roof structures
- High bay and monitor type.
- Multi storey building.
- Special type.

The buildings may have different roof structure as given below.

Figure 11.10 : Types of building

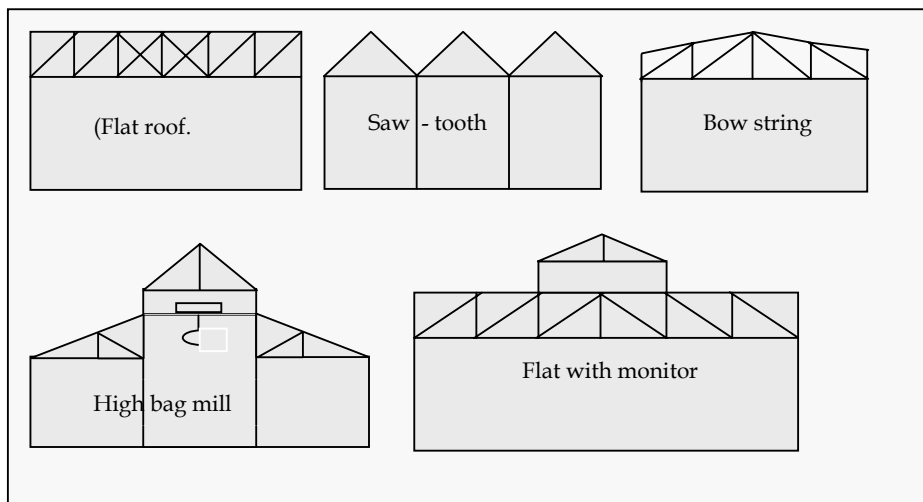

### Single storey building

This construction is preferred on the basis of site and availability of land. The following advantages are offered by single storey building :

- Provide less operating cost
- Provide greater flexibility for layout
- Provides ease in maintenance of the building and equipment

### High bay and monitor type

It is also single storey building designed in such a way that it can carry maximum overhead space. These are popular in big foundries and steel mills. The following advantages are offered:

- Easy to get natural light and natural ventilation
- Easy to accommodate overhead cranes and other handling facilities

### Multi storey buildings

Such buildings are preferred where the cost of land and construction are very high. In designing such buildings, the vibrations and load carrying capacity are the main consideration. The following are the main features of these buildings.

- Can be used for manufacturing light goods or for chemical, food processing industries. It is not preferred for heavy goods.
- Material handling is expensive and specially fast moving materials make it more complex
- Flexibility is hampered
- Natural lights and ventilations are available
- Gravity flow of material are possible like in flour mills .

### Specials type

Some time industrial buildings are the compromise of the above types depending on requirements of the process .

### 11.12.3 TYPES OF CONSTRUCTION

Any industrial building may have the following type of construction.

**Wooden frames:** These days' wooden frames are outdated and are seldom used. It is dangerous of fire and high insurance rate. These buildings too have the short life compared to others.

**Brick construction:** It is very common and cheap construction type and abundantly used. The walls are generally made of bricks and plastered. They are fire proof and more durable than the wooden structure.

**Steel frames:** It make use of still girders, columns, and trusses. Space between the columns are filled by bricks. Such construction are flexible, durable, fire proof, low maintenance cost and thus are very popular.

**Reinforced concrete :** It is the most popular type of construction. It require low capital investment, and low depreciation. Commonly columns and floors are made of concrete and the joining walls are made of bricks. Precast concrete can also be used.